

TGD N-Channel Enhancement Mode Power MOSFET

**Description**

The TGD15H15T uses advanced trench technology and design to provide excellent  $R_{DS(ON)}$  with low gate charge. It can be used in Automotive applications and a wide variety of other applications.

**General Features**

- $V_{DSS} = 150V, I_D = 150A$   
 $R_{DS(ON)} < 8m\Omega @ V_{GS} = 10V$  (Typ: 6.6 m $\Omega$ )
- Good stability and uniformity with high  $E_{AS}$
- Special process technology for high ESD capability
- High density cell design for ultra low  $R_{dson}$
- Fully characterized avalanche voltage and current
- Excellent package for good heat dissipation

**Application**

- Automotive applications
- Hard switched and high frequency circuits
- Uninterruptible power supply

**100% UIS TESTED!**

**100%  $\Delta V_d$ s TESTED!**

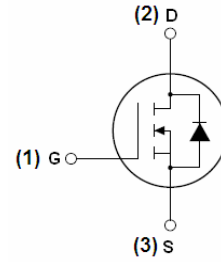

Schematic diagram

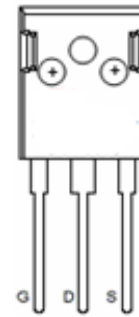

pin assignment



TO-247 top view

**Package Marking and Ordering Information**

Device Marking	Device	Device Package	Reel Size	Tape width	Quantity
15H15T	15H15T	TO-247	-	-	-

**Absolute Maximum Ratings ( $T_C = 25^\circ C$  unless otherwise noted)**

Parameter	Symbol	Limit	Unit
Drain-Source Voltage	$V_{DSS}$	150	V
Gate-Source Voltage	$V_{GS}$	$\pm 20$	V
Drain Current-Continuous	$I_D$	150	A
Drain Current-Continuous( $T_C = 100^\circ C$ )	$I_D (100^\circ C)$	106	A
Pulsed Drain Current	$I_{DM}$	600	A
Maximum Power Dissipation	$P_D$	460	W
Derating factor		3.07	W/ $^\circ C$
Single pulse avalanche energy <sup>(Note 3)</sup>	$E_{AS}$	3100	mJ
Peak Diode Recovery $dv/dt$ <sup>(Note 4)</sup>	$dv/dt$	18.5	V/ns



Operating Junction and Storage Temperature Range	$T_J, T_{STG}$	-55 To 175	°C
--	----------------	------------	----

**Thermal Characteristic**

Thermal Resistance, Junction-to-Case <sup>(Note 1)</sup>	$R_{\theta JC}$	0.33	°C/W
--	-----------------	------	------

**Electrical Characteristics ( $T_C=25^\circ\text{C}$  unless otherwise noted)**

Parameter	Symbol	Condition	Min	Typ	Max	Unit
<b>Off Characteristics</b>						
Drain-Source Breakdown Voltage	$BV_{DSS}$	$V_{GS}=0V, I_D=250\mu A$	150	170	-	V
Zero Gate Voltage Drain Current	$I_{DSS}$	$V_{DS}=150V, V_{GS}=0V$	-	-	1	$\mu A$
Gate-Body Leakage Current	$I_{GSS}$	$V_{GS}=\pm 20V, V_{DS}=0V$	-	-	$\pm 200$	nA
<b>On Characteristics</b>						
Gate Threshold Voltage	$V_{GS(th)}$	$V_{DS}=V_{GS}, I_D=250\mu A$	2	3	4	V
Drain-Source On-State Resistance	$R_{DS(ON)}$	$V_{GS}=10V, I_D=40A$	-	6.6	8	m $\Omega$
Forward Transconductance	$g_{FS}$	$V_{DS}=50V, I_D=40A$	150	-	-	S
<b>Dynamic Characteristics</b>						
Input Capacitance	$C_{iss}$	$V_{DS}=25V, V_{GS}=0V,$ $F=1.0MHz$	-	21000	-	PF
Output Capacitance	$C_{oss}$		-	1446	-	PF
Reverse Transfer Capacitance	$C_{rss}$		-	1120	-	PF
<b>Switching Characteristics</b>						
Turn-on Delay Time	$t_{d(on)}$	$V_{DD}=30V, I_D=2A, R_L=15\Omega$ $V_{GS}=10V, R_G=2.5\Omega$	-	20	-	nS
Turn-on Rise Time	$t_r$		-	110	-	nS
Turn-Off Delay Time	$t_{d(off)}$		-	45	-	nS
Turn-Off Fall Time	$t_f$		-	70	-	nS
Total Gate Charge	$Q_g$	$V_{DS}=30V, I_D=30A$ $V_{GS}=10V$	-	586	-	nC
Gate-Source Charge	$Q_{gs}$		-	123	-	nC
Gate-Drain Charge	$Q_{gd}$		-	184	-	nC
<b>Drain-Source Diode Characteristics</b>						
Diode Forward Voltage	$V_{SD}$	$V_{GS}=0V, I_S=40A$	-	-	1.2	V
Reverse Recovery Time	$t_{rr}$	$T_J = 25^\circ\text{C}, I_F = 75A$ $di/dt = 100A/\mu s$ <sup>(Note2)</sup>	-	71	-	nS
Reverse Recovery Charge	$Q_{rr}$		-	106	-	nC
Forward Turn-On Time	$t_{on}$	Intrinsic turn-on time is negligible (turn-on is dominated by LS+LD)				

**Notes:**

1. Surface Mounted on FR4 Board,  $t \leq 10$  sec.
2. Pulse Test: Pulse Width  $\leq 400\mu s$ , Duty Cycle  $\leq 2\%$ .
3. EAS condition:  $T_J=25^\circ\text{C}, V_{DD}=75V, V_G=10V, L=0.5mH, R_G=25\Omega$
4.  $I_{SD} \leq 125A, di/dt \leq 260A/\mu s, V_{DD} \leq V_{(BR)DSS}, T_J \leq 175^\circ\text{C}$

**Test circuit**

**1) E<sub>AS</sub> test Circuits**

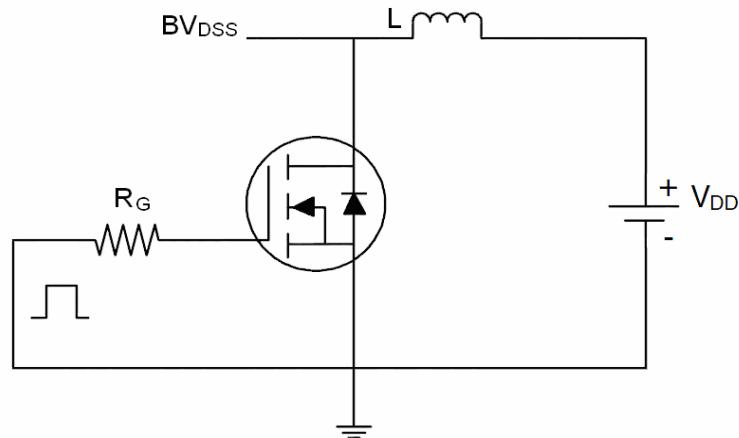

**2) Gate charge test Circuit:**

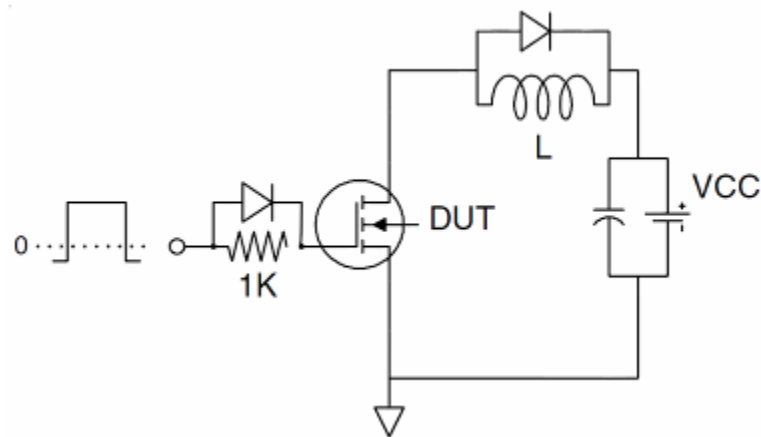

**3) Switch Time Test Circuit:**

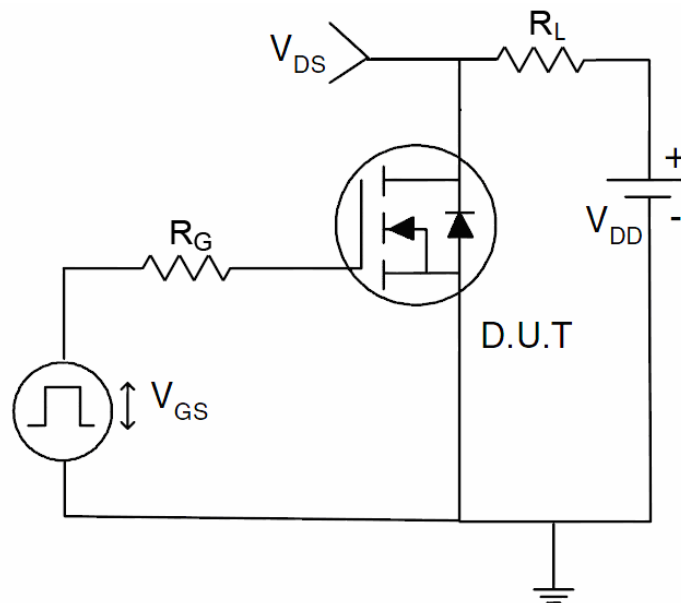

Typical Electrical and Thermal Characteristics

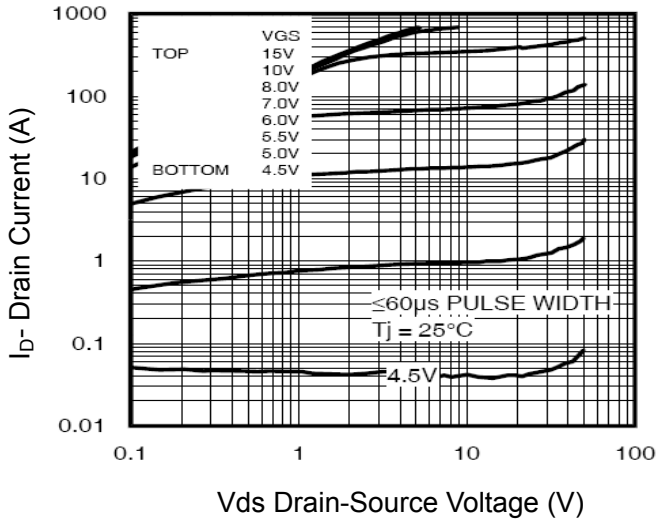

Figure 1 Output Characteristics

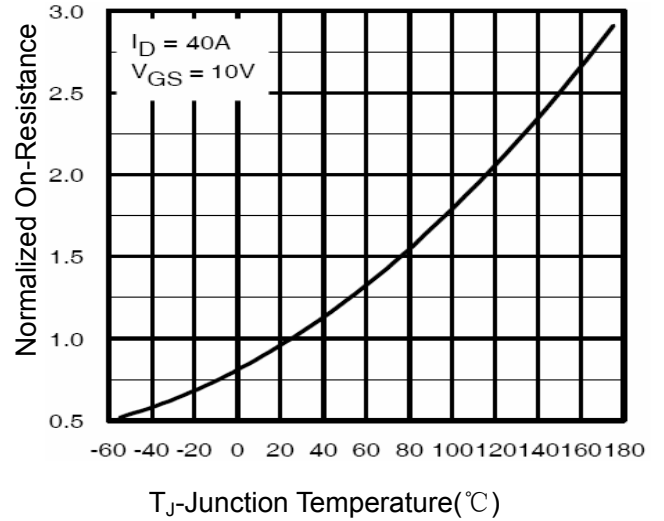

Figure 4 Rdson-Junction Temperature

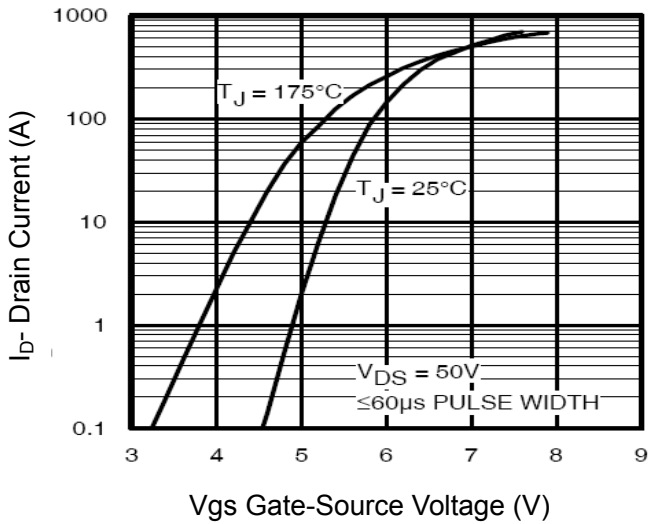

Figure 2 Transfer Characteristics

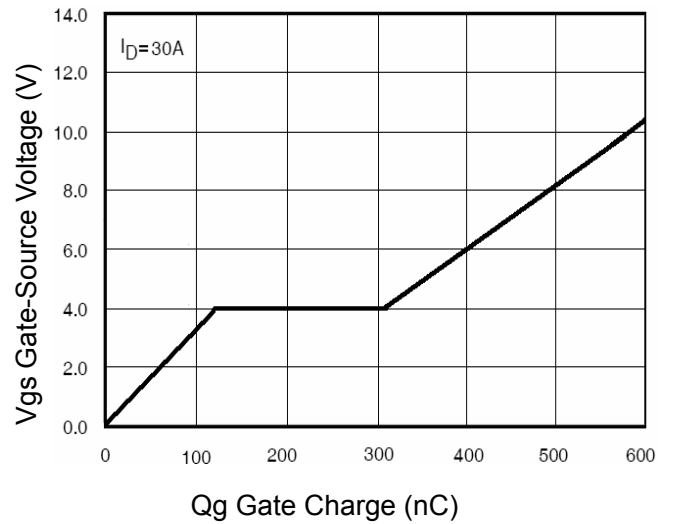

Figure 5 Gate Charge

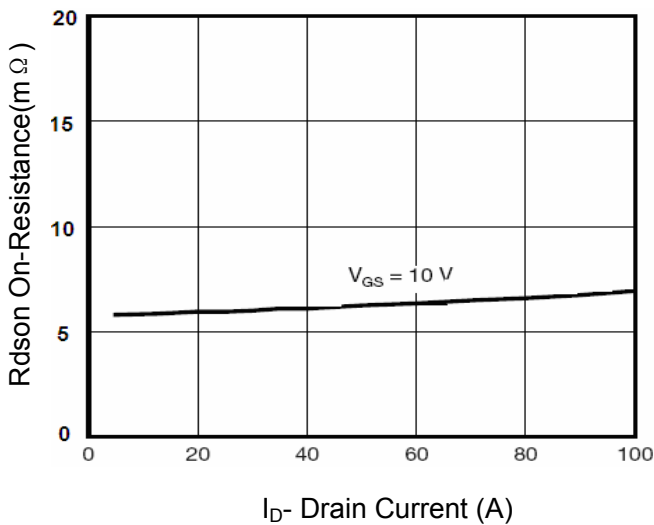

Figure 3 Rdson- Drain Current

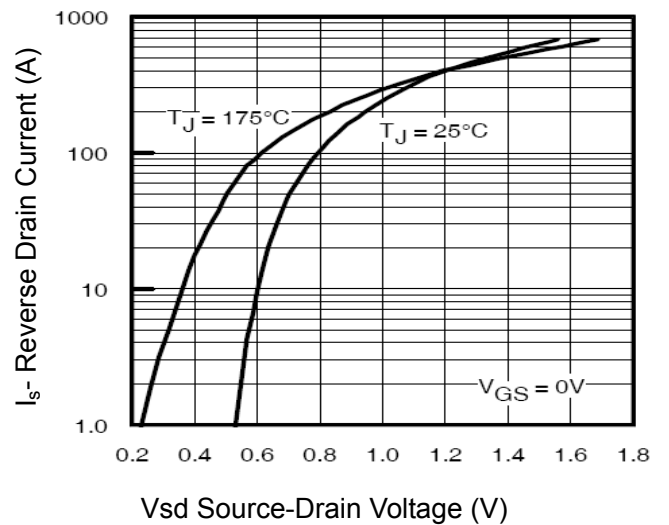
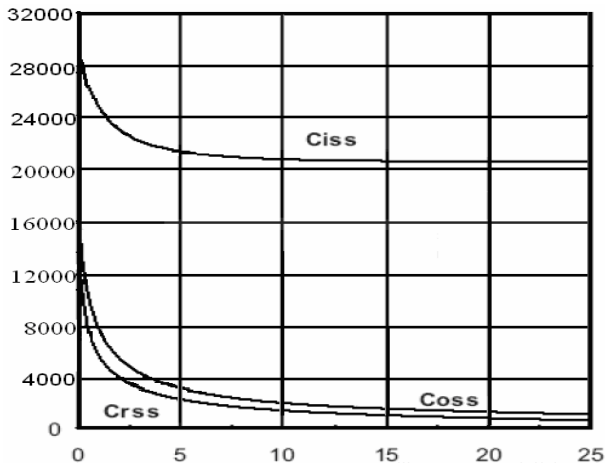
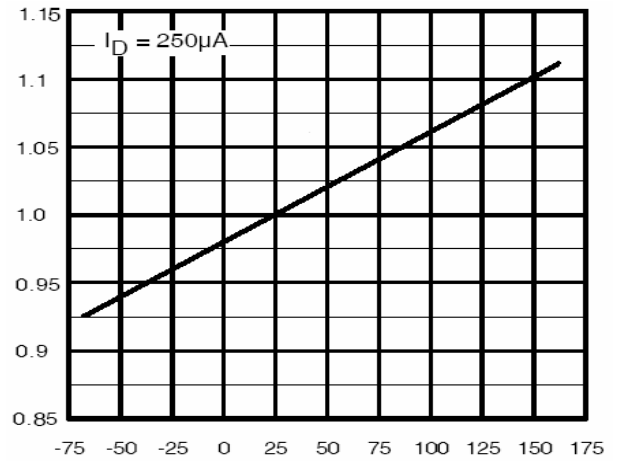

Figure 6 Source- Drain Diode Forward



Vds Drain-Source Voltage (V)  
**Figure 7 Capacitance vs Vds**



T<sub>J</sub>-Junction Temperature(°C)  
**Figure 9 BV<sub>DSS</sub> vs Junction Temperature**

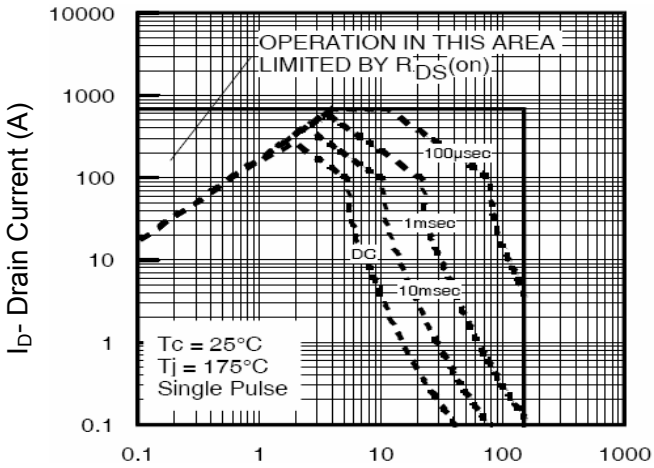

Vds Drain-Source Voltage (V)  
**Figure 8 Safe Operation Area**

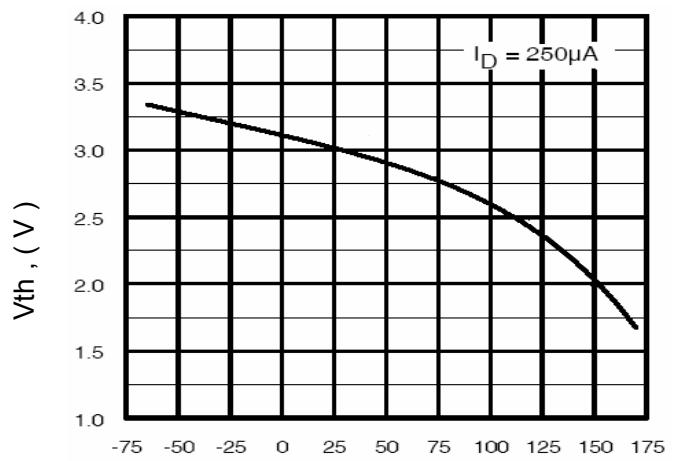

T<sub>J</sub>-Junction Temperature(°C)  
**Figure 10 V<sub>GS(th)</sub> vs Junction Temperature**

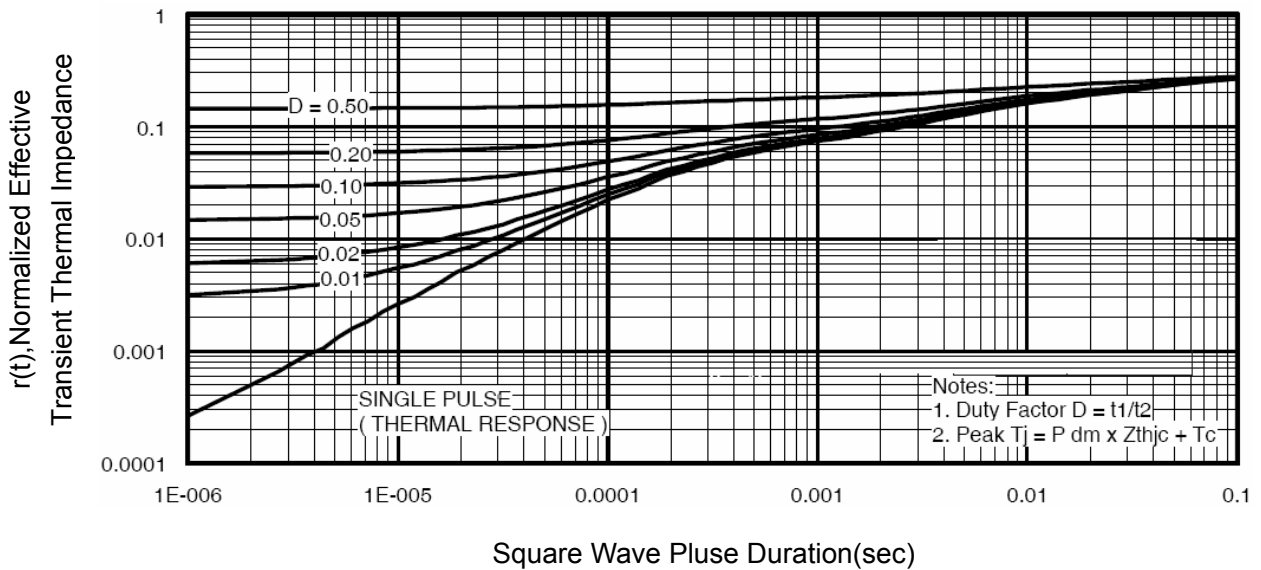

Square Wave Pulse Duration(sec)  
**Figure 11 Normalized Maximum Transient Thermal Impedance**



TO-247 Package Information

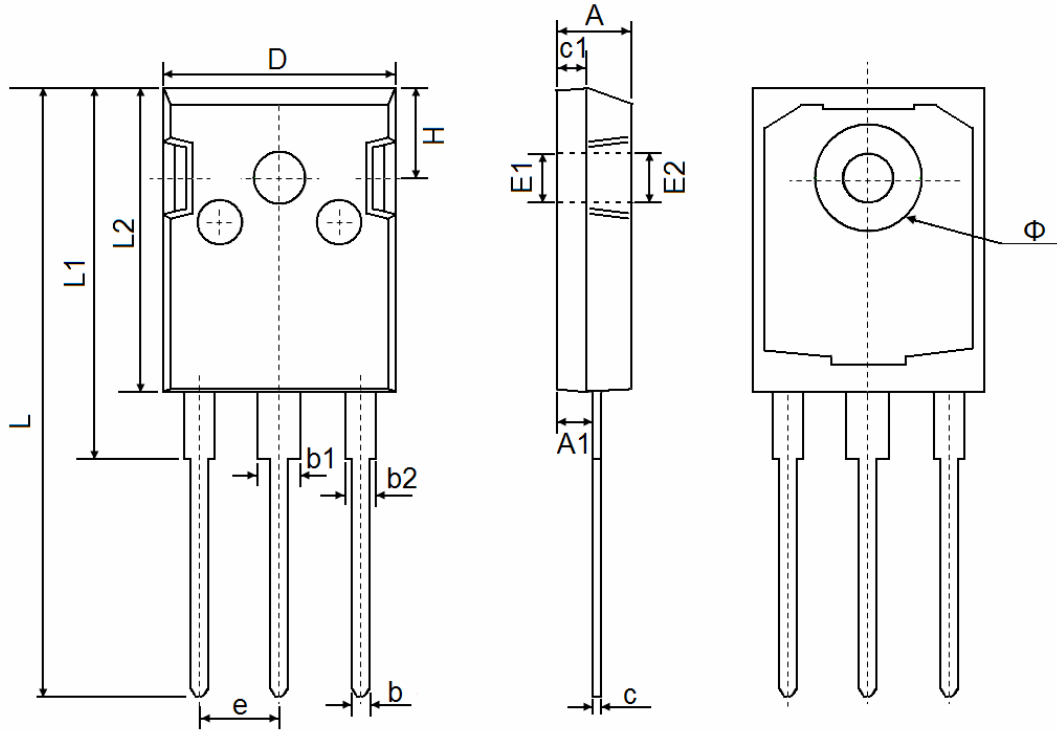

Symbol	Dimensions In Millimeters		Dimensions In Inches	
	Min.	Max.	Min.	Max.
A	4.850	5.150	0.191	0.200
A1	2.200	2.600	0.087	0.102
b	1.000	1.400	0.039	0.055
b1	2.800	3.200	0.110	0.126
b2	1.800	2.200	0.071	0.087
c	0.500	0.700	0.020	0.028
c1	1.900	2.100	0.075	0.083
D	15.450	15.750	0.608	0.620
E1	3.500 REF		0.138 REF	
E2	3.600 REF		0.142 REF	
L	40.900	41.300	1.610	1.626
L1	24.800	25.100	0.976	0.988
L2	20.300	20.600	0.799	0.811
Φ	7.100	7.300	0.280	0.287
e	5.450 TYP		0.215 TYP	
H	5.980 REF		0.235 REF	